



FLOORING SOLUTIONS

# PEARL

ACCEPT NO IMITATIONS™



*QUALITY TOOLS FOR FLOORING  
PREPARATION AND TILE INSTALLATION*

- *Flooring Removal and Surface Preparation*
  - *Dust Containment Systems / HEPA Vacuums*
  - *Cutting and Drilling*
  - *Underlayment and Spacing*
  - *Leveling*
- 

# 15" HEXPLATES™ FOR 17" OR 18" BUFFERS



The Pearl Hexpin® System has revolutionized floor preparation. Use the standard Hexpin® Plates with our patented system of interchangeable Hexpins® for grinding, sanding, polishing and coating removal.



WATCH THE VIDEO AT:  
[PearlAbrasive.com](http://PearlAbrasive.com)



Shown with polishing pads

Shown with Turbo-Cut™

Shown with scrape and grind pads

Shown with diamond segmented pads

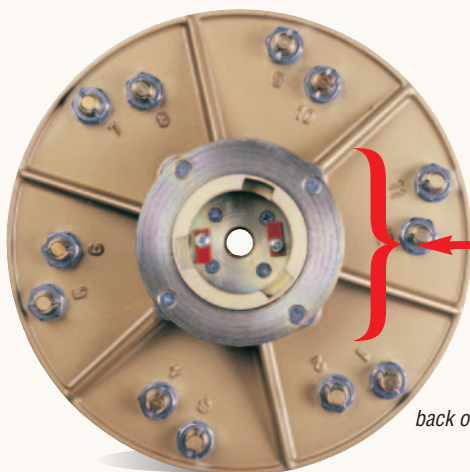

back of 15" plate

## SUPERCLUTCH™

**SAFELY PREVENTS COUPLER  
BREAKAGE AND BUFFER DAMAGE.**

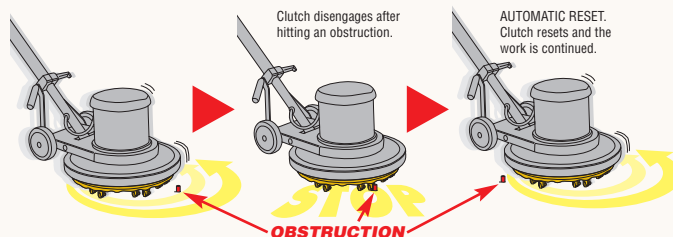

- SuperClutch™ will disengage if the Hexpin® Plate hits an obstruction (i.e. bolts).
- SuperClutch™ is self resetting.
- Manually resetting torque locks (red tabs) inside clutch housing will keep clutch from disengaging.

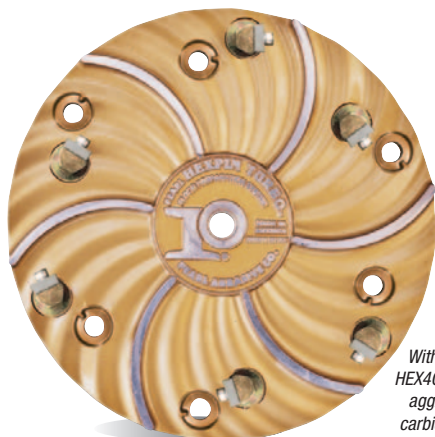

With six #4  
HEX4CHIP very  
aggressive  
carbide chips

## 15" HEXPLATE™ SPEED SCRAPER

- For 1.5 HP 175 RPM machines. Turn lock hub fits most machine brands
- Six #4 HEX4CHIP very aggressive chips. Available with or without SuperClutch™
- Durable, solid cast aluminum base plate, fluted for dust control
- Spring-loaded tool holders for maximum floor contact
- Interchangeable tools available for scraping, sanding, grinding, polishing concrete

PT. NUMBER	SPECS
HEX1706CBD	15" plate with 6 carbide #4 chips
HEX1706CBDCLT	15" plate with 6 carbide #4 chips with SuperClutch™



## 15" HEXPLATE™ WITHOUT SUPERCLUTCH™

PT. NUMBER	SPECS
HEX1706SG	15" plate with 6 scrape/grind pads
HEX1712SG	15" plate with 12 scrape/grind pads
HEX1706EZ	15" plate with 6 diamond EZ pads
HEX1712EZ	15" plate with 12 diamond EZ pads
HEX1764	15" plate with 6 diamond segmented pads
HEX1712	15" plate with 12 green diamond pins (gen. purpose)
HEX1712C*	15" plate with 12 gold diamond pins (coarse diamonds)
HEX1712B	15" plate with 12 blue diamond pins (hard bonded)
HEX17CBD	15" plate with 12 carbide pins
HEX17QC	15" plate with 6 quick change pins
HEX17FTC*	15" plate with 6 turbo cut pins
HEX17BPD	15" plate with 6 hook and loop backing pads
HEX17CUP	15" plate with 6 diamond cups
HEX17CBD3	15" plate with 12 carbide #3 cutter pins
<b>PRODUCTION KITS</b>	
HEX17KTG*	1 HEX17CBD Plate and 12 HEX1PNG pins
HEX17KTC*	1 HEX17CBD Plate and 12 HEX1PNC pins
HEX17KTT	1 HEX17CBD Plate and 6 HEX1FTC pins

## 15" HEXPLATE™ WITH SUPERCLUTCH™

PT. NUMBER	SPECS
HEX1706SGCLT	15" plate w/ clutch and 6 scrape/grind pads
HEX1712SGCLT	15" plate w/ clutch and 12 scrape/grind pads
HEX1706EZCLT	15" plate w/ clutch and 6 diamond EZ pads
HEX1712EZCLT	15" plate w/ clutch and 12 diamond EZ pads
HEX1764CLT	15" plate w/ clutch and 6 diamond segmented pads
HEX1712CLT	15" plate w/ clutch and 12 green diamond pins (gen. purpose)
HEX1712CCLT	15" plate w/ clutch and 12 gold diamond pins (coarse)
HEX1712BCLT*	15" plate w/ clutch and 12 blue diamond pins (hard bonded)
HEX17CBDCLT	15" plate w/ clutch and 12 #1 carbide chip
HEX17QCCLT	15" plate w/ clutch and 6 quick change pins
HEX17FTCCLT	15" plate w/ clutch and 6 turbo cut pins
HEX17BPDCLT	15" plate w/ clutch and 6 hook and loop backing pads
HEX17CUPCLT	15" plate w/ clutch and 6 diamond cups
HEX17CBD3CLT	15" plate w/ clutch and 12 #3 carbide chips
HEX17CBD4CLT	15" plate w/ clutch and 12 #4 carbide chip
HEX17CLTH	15" plate w/ clutch only
HEX1CLUTCH	SuperClutch™ only

### CARBIDE CHIPS ATTACHMENT

Designed and fitted with a replaceable, four sided, abrasion resistant, carbide insert. Use for scraping and removal of a variety of coatings and paints from concrete surfaces



ALSO AVAILABLE IN  
**12/PACK!**

#### #1 CARBIDE CHIP

#HEX1CHIP  
#HEX1CHIP12 (12/pack)

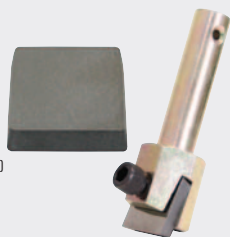

Use in removing thinset, mastics, glue, rubber or foam backed carpet residue, dirt buildup, ice and paint.

#### #3 AGGRESSIVE CARBIDE CHIP

#HEX3CHIP  
#HEX3CHIP12 (12/pack)

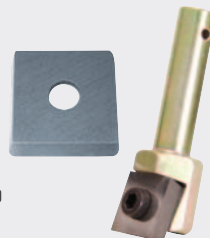

Useful when taking up unusually difficult-to-remove mastics and glue. The chip has a hole to secure the chip when working in rough conditions.

#### #4 VERY AGGRESSIVE CARBIDE CHIP

#HEX4CHIP  
#HEX4CHIP12 (12/pack)

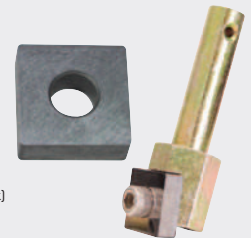

WITH 8 SHARP EDGES! Best used to remove thin paint and epoxy from concrete, but works well for other concrete surface removal applications.

### DIAMOND EZ PADS ATTACHMENT

#HEX1EZPAD

Attaches fast and easy to Hexpin® carbide holder! EZ pads can only be used on carbide holder #HEX1CRBH.



- Cost effective diamond attachment for Hexpin®
- Fits into #1 carbide chip holder
- 6 or 12 EZ pads can be used
- Spring mounted pins allow for uneven surfaces
- Excellent for sanding, light grinding and floor preparation on concrete
- Can be used wet or dry on concrete surfaces

NO NEED to remove all chips or holders as the Hexpin® EZ pad is high enough to provide clearance so the carbide chips do not touch the work surface.

### SCRAPE AND GRIND PADS ATTACHMENT

#HEX1SGPAD

Now you are ready to scrape away mastic, thinset and other materials and grind concrete!

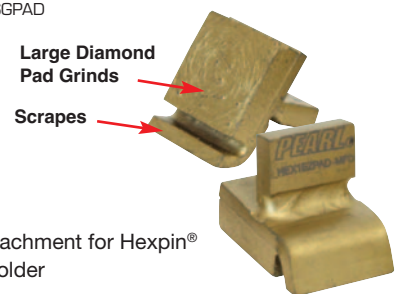

- Cost effective diamond attachment for Hexpin®
- Fits into #1 carbide chip holder
- 6 or 12 pads can be used
- Spring mounted pins allow for uneven surfaces
- Can be used wet or dry on concrete surfaces

The Pearl SCRAPE AND GRIND pads attachment scrapes away mastic, thinset, etc. and grinds the concrete at the same time. Just remove the carbide chips from the HEX1CRBH holder and install the Scrape and Grind attachment. Patent pending.



WARNING: Cancer and reproductive harm  
[www.P65Warnings.ca.gov](http://www.P65Warnings.ca.gov)

(\* ) Indicates a special order item. Short lead times on most items. Please call for availability.  
To order, call: U.S.A. 800-969-5561 • Canada 800-387-0008 • PearlAbrasive.com

**PEARL**

## DIAMOND SEGMENTED PADS ATTACHMENT #HEX4PAD-MFD

20% MORE GRINDING SURFACE AREA THAN THE COMPETITION!

Pearl's diamond segmented pad (HEX4PAD-MFD) designed to be used on the 15" Hexplate™. They are made with an overall larger grinding/sanding area which increases production. When attached to the 15" Hexplate™, the new and improved Diamond Segmented Pads extend past the edge of the plate allowing the operator to GRIND OR SAND RIGHT UP TO THE EDGE OF THE WALL.

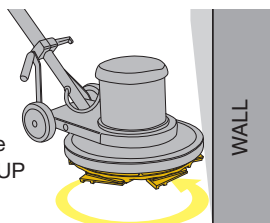
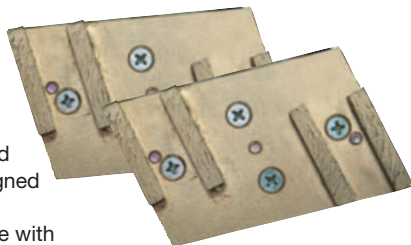

- Use with your standard Hexpin® plates & block
- Faster and more aggressive grinding
- Wide diamond segments mean longer life
- Easily removes trowel marks
- Smooths rough finishes
- Provides texture to slippery surfaces
- Prepares concrete surfaces for coatings
- Removes sealers and bond breaker coatings

## TURBO-CUT™ HEXPIN® ATTACHMENT #HEX1FTC

Specially engineered for coating removal where abrasive grains are more effective than customary scraping methods. Suited for light scarification of coated surfaces, removal of urethane and rubberized coatings, sealers and light rust from metal surfaces.



ALSO AVAILABLE IN 6/PACK!



## 3" DRY CONCRETE POLISHING PADS HOOK & LOOP ATTACHMENT

Available in 30, 50, 100, 200, 400, 800, 1500 and 3000 grit.

Also available in 6/pack kit

Recommended Speed:

150 - 200 RPM

Max Speed: 2,000 RPM



## HEX-CUP™ ATTACHMENT #HEX1CUP

Superior grinding on flat slab surfaces.



## WET DIAMOND DISC PADS ATTACHMENT

Polishing disc pads can be used for polishing marble and granite floors.



## DIAMOND HEXPIN™ ATTACHMENT

Designed to be used for grinding and sanding concrete surfaces.



## 10" SURFACE GRINDING PLATE

#HEX1GHP10 - 10 SEGMENTS  
#HEX1GHP20 - 20 SEGMENTS



Designed for grinding concrete. They are excellent for aggressive stock removal and give rough concrete surfaces the smoothest finish in the quickest time. Can be used on single or double-head floor machines.

- Available in 10 or 20 segments.
- Wet or dry use. Fast grinding. Long life.

## 16" DOUBLE-SIDED TUNGSTEN CARBIDE SANDING DISC

#CCDO16P

*Excellent for removal of paint, carpet adhesive, epoxy and more!*

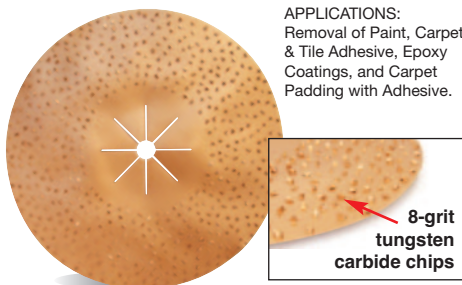

APPLICATIONS:  
Removal of Paint, Carpet & Tile Adhesive, Epoxy Coatings, and Carpet Padding with Adhesive.

Engineered with 8-grit tungsten carbide chips which can be cleaned and used many times. Pearl's tungsten carbide sanding disc is ideal for use on Pearl's Sanding Disc attachment and with any 17" floor buffer.

## 16" SANDING PLATE ATTACHMENT

#BUFSPL16

*Dense heavy duty felt. Rated #1 in density.*

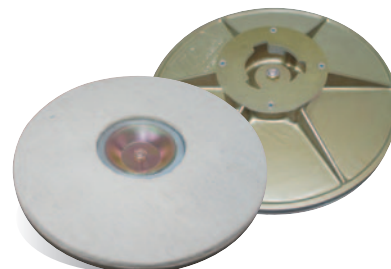

Heavy duty aluminum plate. 3/8" thick felt pad. Durable metal center casting. For use on 17"-18" floor buffer machines. It includes our HEX1CLP clutch plate to fit most floor machines.

# DIAMOND CUP WHEELS

- Swirl cup provides smoother finishes than row cup wheel
- Less segments - For aggressive stock and coating removal
- Turbo cup for fast, smooth grinding

## Special-shaped Segmented Cup Wheels

For removing adhesives, light concrete grinding.

### V - ARROW



### T - SEG



PT. NUMBER	SPECS	MAX RPM
DC4CVH	4 x 5/8-11	13,700
DC5CVH	5 x 5/8-11	12,200
DC7CVH	7 x 5/8-11	8,500

V-Arrow-shaped segments designed for aggressive grinding. Great for epoxy, paint, mastics, and coating removal. Wet or dry grinding.

PT. NUMBER	SPECS	MAX RPM
DC4CTH	4 x 5/8-11	13,700
DC5CTH	5 x 5/8-11	12,200
DC7CTH	7 x 5/8-11	8,500

The "T" segment design has more surface area contact that gives the operator more control with less opportunity to dig into the floor. Wet or dry grinding.

For Concrete, Block, Stone and Other Masonry Products

For grinding concrete, block, stone and other masonry products.

### P2 PRO-V™



PT. NUMBER	SPECS
PV04CSEH	4 x 5/8-11 (8 SEGMENTS)
PV04CSH	4 x 5/8-11 (14 SEGMENTS)
PV05CSEH	5 x 5/8-11 (9 SEGMENTS)
PV07CSEH	7 x 5/8-11 (12 SEGMENTS)
PV07CSH	7 x 5/8-11 (24 SEGMENTS)

### P5™ TURBO



PT. NUMBER	SPECS
PW4C	4 x 7/8, 5/8 (COARSE)
PW4CH	4 x 5/8-11 (COARSE)
PW4M	4 x 7/8, 5/8 (MEDIUM)
PW4MH	4 x 5/8-11 (MEDIUM)
PW4F	4 x 7/8, 5/8 (FINE)
PW6CH	6 x 5/8-11 (COARSE)



FLOORING REMOVAL AND SURFACE PREPARATION



WARNING: Cancer and reproductive harm  
www.P65Warnings.ca.gov

(\*) Indicates a special order item. Short lead times on most items. Please call for availability.  
To order, call: U.S.A. 800-969-5561 • Canada 800-387-0008 • PearlAbrasive.com

**PEARL**

# VACU-GUARD™ UNIVERSAL DUST SHROUDS

For dust control when grinding concrete, masonry and mortar  
Connects to all commercial vacuums • Easy to install

**NEW!**

FOR 7" & 9" GRINDERS  
#VAC7OEP



HINGED  
NOSE

7" has bottom metal support at the bottom to keep shroud shape and longer life.

**NEW!**

FOR 4.5" & 5" GRINDERS  
#VAC5OEP

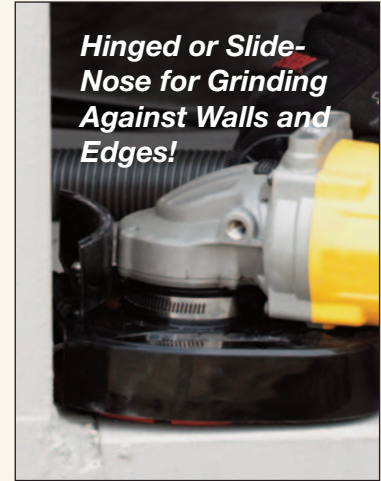

**Hinged or Slide-  
Nose for Grinding  
Against Walls and  
Edges!**

**NEW!**

FOR 7" & 9" GRINDERS  
#VAC7OEPS

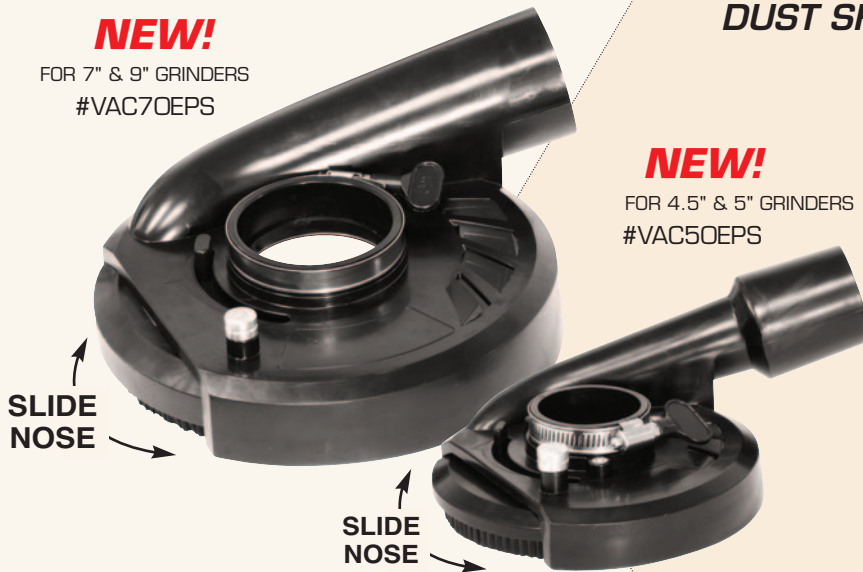

SLIDE  
NOSE

SLIDE  
NOSE

**NEW!**

FOR 4.5" & 5" GRINDERS  
#VAC5OEPS

## DUST SHROUDS WITH SLIDE NOSE!



Slide nose brushes allows smooth operation when opening and closing. Also gives flexibility on the surface when closed.



Unique air slots allowing air to flow evenly through shroud for efficiency.



Durable material for flexibility and longevity.

Built-in Locking Pin to release and to lock the nose in place.



Bottom metal support at the bottom to keep shroud shape and longer life.

### SHROUDS FOR 7" & 9" GRINDERS

Designed to fit 7" and 9", 15 amp grinders, up to 7" cup wheels: Milwaukee, Dewalt, Metabo, Hitachi, Makita, and Bosch

Included with each shroud:  
Shroud clamp,  
Shroud spacers (5)

Vacuum port size:  
2.25 ID; 2.65 O.D.



### SHROUDS FOR 4-1/2" & 5" GRINDERS

Designed to fit 4-1/2" and 5" grinders: Milwaukee, Dewalt, Metabo, Makita, and Bosch

Included with each shroud:  
Shroud clamp, Shroud spacer (1)  
and washers

Vacuum port size:  
1.75 ID; 2.0 O.D.



# VACU-GUARD™ DUST SHROUDS

For dust control when grinding concrete, masonry and mortar. Connect to a commercial vacuum. • Easy to install.



FOR 7" & 9" GRINDERS  
#VAC70E



### Hinged Nose for Grinding Against Walls and Edges!

No tools are required  
For 7" & 9", 15 amp grinders:  
Milwaukee, Dewalt, Metabo,  
Hitachi, Makita, and Bosch  
Includes shroud clamp,  
shroud spacers (set of 5)

FOR 4" TO 5" GRINDERS  
#VAC50EV



### Slide-Nose Dust Shroud for Grinding Against Walls and Edges!

Made from durable injection molded polymer  
Bottom brushes for flexibility to follow surface  
contours and to maintain suction  
For Milwaukee, Dewalt, Metabo, Makita  
and Bosch grinders  
Includes clamp, cup nut assembly, and  
vacuum adapter

FOR 4.5" & 5" GRINDERS  
#VAC50E



Designed to fit 4-1/2"  
and 5" grinders:  
Milwaukee, Dewalt,  
Metabo, Makita, and  
Bosch  
Includes clamp, cup  
nut assembly

Cup Nut Assembly - Allows for necessary spacing and nut adjustments for various cup wheels.  
Universal fit guards - includes all parts needed to fit grinder models shown.

## VACU-GUARD™ DUST CONTAINMENT FOR 4-1/2" AND 7" GRINDERS

Available with tungsten carbide wear pads for longer life! Durable and effective dust containment system. For grinding only. Adapts easily to a variety of angle grinders. Pearl's exclusive flexible diaphragm allows the operator to adjust the grinder angle without sacrificing dust containment efficiency. A special Delrin seal strip allows the unit to flow easily over a variety of surfaces.



PT. NUMBER	PT. NUMBER WITH CARBIDE PADS	SPECS	RING SIZE (I.D.)
VACGR45	VACGR45C	4-1/2" Vacu-Guard™ for Dewalt® & Black & Decker®	1.6"
VACGR45B	VACGR45BC	4-1/2" Vacu-Guard™ for Bosch® & Makita®	1.7"
VACG45ME	VACG45MEC	4-1/2" Vacu-Guard™ for Metabo®	2.0"
VACGR45DE	VACGR45DEC	4-1/2" Vacu-Guard™ for Dewalt® DW28402 & DW818	1.755"
VACGRDE	VACGRDEC	7" Vacu-Guard™ Dewalt® D28494S, D28494N	2.375"
VACGRBO	VACGRBOC	7" Vacu-Guard™ for Bosch® & Milwaukee®	2.95"
VACGRMH	VACGRMHC	7" Vacu-Guard™ for Metabo® & Hitachi®	2.95" +2.52 ring
VACGR01	VACGR01C	7" Vacu-Guard™ - use with Makita® GA 7911 or GA 700IL, Black & Decker®, Dewalt™	2.125"

Ask us about Vacu-Guards™ to fit other popular grinders.

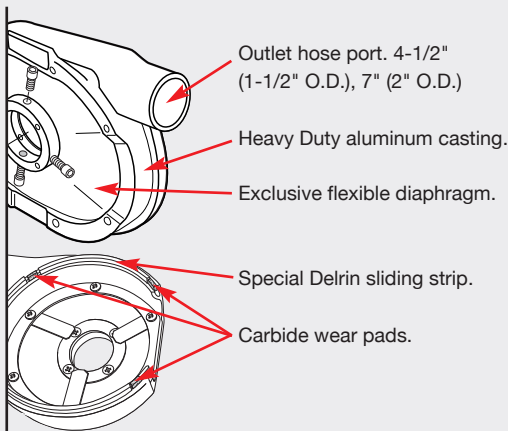

FEATURES	BENEFITS
<b>Exclusive Flexible Diaphragm.</b>	Allows the operator to adjust the grinder angle without sacrificing dust containment efficiency.
<b>Special Delrin Sliding Strip.</b>	Allows Vacu-Guard™ to slide easily over a variety of surfaces.
<b>Heavy Duty Aluminum Casting.</b>	Lightweight, long lasting and durable.
<b>Carbide Wear Pads.</b>	Protects the Delrin slide from excessive wear, thus increasing life.
<b>Adjustable Hub Adapters.</b>	Able to adapt to a variety of angle grinders.



WARNING: Cancer and reproductive harm  
www.P65Warnings.ca.gov

(\*) Indicates a special order item. Short lead times on most items. Please call for availability.  
To order, call: U.S.A. 800-969-5561 • Canada 800-387-0008 • PearlAbrasive.com



# V-MAX™

## INDUSTRIAL HEPA VACUUM CLEANERS

#PAV-26 and #PAV-36

- Compliant with OSHA's respirable crystalline dust standards
- Heavy-duty construction
- Ideal for power tools, 17" floor machines, walk-behind saws, 20"-25" concrete grinding and polishing machines and construction cleanup
- HEPA Filtration for improved indoor air quality
- Mess-free dust disposal with Pearl continuous bagging system
- Air pulse filter cleaning system efficiently purges the pre-filter within the closed vacuum
- 2 (PAV-26) or 3 (PAV-36) switch system allows you to activate each motor independently
- Certified cylindrical shaped HEPA filter guaranteed 99.99% efficient at 0.3 microns
- 2" hose inlet and 33' hose
- Large heavy-duty wheels for easy transport over power cords and other floor obstructions
- Manometer, measures the negative pressure within the tank and alerts the operator when filter needs service
- Hour meter, helps to monitor HEPA filter life
- Two-year limited warranty



PAV-36

PAV-26

### SPECIFICATIONS:

Model	V-MAX™ PAV-26	V-MAX™ PAV-36
Voltage/Hz	110V/60HZ	220V/60HZ
Power	3.4 HP	5.1 HP
Airflow	258 CFM	353 CFM
Max Air Pressure	100" H2O	100" H2O
QTY of 1st Stage Filters (unit)	1	1
QTY of 2nd Stage Filters (unit)	2	3
Air Inlet	2" (standard)	2" (standard)
Noise	82±2dB	82±2dB
Filter Efficiency	99%	99%
Material of 1st Filter	Anti-static material	Anti-static material
Material of 2nd Filter	Imported TORAY	Imported TORAY
Filter Fineness	0.3-3 microns	0.3-3 microns
Main Filtering Method	Outer-filtering type for 1st stage filter Inner-filtering type for 2nd stage filter	Outer-filtering type for 1st stage filter Inner-filtering type for 2nd stage filter
Dimension	31" x 23" x 47"	36" x 23" x 53"
Weight	181 lbs.	216 lbs





# V-MAX™ FEATURES AND BENEFITS:



## FRAME CONSTRUCTION

Heavy-duty construction for industrial applications.

- Box frame with heavy gauge steel.
- All metal motor housing.
- Heavy-duty replaceable steel parts that withstand the worst environments.



## AIR FLOW

Higher air flow compared to other vacuums. PAV-26 shown.



## HEPA FILTER ACCESS

Easy access to HEPA filters for replacing or cleaning, no tools required.



## SWITCH SYSTEM

V-Max™ Vac's switch system allows you to activate each motor independently.

- Allows use of one motor for small dust shrouds where high CFM's are not needed.
- Easy access switch panel lets you service the electrical parts by removing 4 screws or 4 knobs.



## FILTER CLEANING SYSTEM

Metal cover to protect filter cleaning system with heavy-duty metal handle.



## PRE-FILTER CLEANING SYSTEM

No need to remove hose to use pre-filter cleaning system.

- Easy access lever.



## POWER CORD

Heavy-duty 25 ft. power cord.



## LATCHES

Heavy-duty replaceable spring loaded latches that place the correct amount of pressure on the seal.



## WHEELS

Heavy-duty swivel caster locking wheels supported with large bolt to box frame.



## INCLUDED HOSE

2 in. x 33 ft. heavy-duty hose.



## HANDLE

Padded handle lets you move vacuum comfortably, and is replaceable.



WARNING: Cancer and reproductive harm  
[www.P65Warnings.ca.gov](http://www.P65Warnings.ca.gov)

(\*) Indicates a special order item. Short lead times on most items. Please call for availability.  
To order, call: U.S.A. 800-969-5561 • Canada 800-387-0008 • [PearlAbrasive.com](http://PearlAbrasive.com)

# TURBO MAX

## 17" PRO BUFFERS

### TURBO MAX HDi #HEX1BFRHDI

**MOTOR** 1-1/2 HP *Sealed* Induction, Dual Capacitor AC Motor and Heavy Duty Planetary Head 1.5 HP, Totally Enclosed Fan Cooled Motor (TEFC)  
110/115v

**AMPS** 13 amps

**WEIGHT** 113 lbs.

**SHIPPING WEIGHT & SIZE** 130 lbs.  
48"H x 26.5"L x 23"W

### TURBO MAX HD #HEX1BFRHD

1-1/2 HP Induction, Dual Capacitor AC Motor and Heavy Duty Planetary Head 1.5 HP Open Drip Proof Motor (ODP)  
110/115v

**AMPS** 14.4 amps

**WEIGHT** 95 lbs.

**SHIPPING WEIGHT & SIZE** 112 lbs.  
48"H x 26.5"L x 23"W



- Dual metal switch levers, left or right hand operation
- Triple planetary steel gears - 175 rpm
- All steel and stainless steel construction
- Optimal weight delivers the right resistance against the floor to get the job done better and faster
- Extremely durable and convenient handle adjustment mechanism is foot operated
- Long 50 ft. heavy duty (14-3) cord with durable spring steel strain relief
- 5" non-marking wheels
- Non-marking PVC bumper prevents marking furniture or walls
- Assembled in the U.S.A.
- 1-year limited warranty



Use with 15" Hexplates

### KITS

**PART# HEXHDIKIT**  
Includes: HEX1BFRHDI and BUFVAC1 Vac Kit

**PART# HEXHDKIT**  
Includes: HEX1BFRHD and BUFVAC1 Vac Kit

### ACCESSORIES AVAILABLE:



Dust Vac Kit  
#BUFVAC1



4 Gal. Solution Tank  
#BUFTNK02

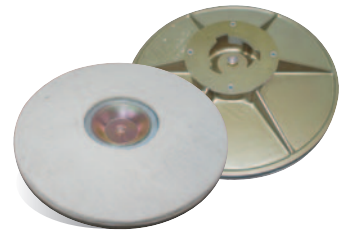

Felt Sanding Plate  
#BUFSP16



Horseshoe Weight 14 lbs.  
#HEX14LBS  
and Post #HP02PIN

# PEARL

## PROFESSIONAL TILE SAWS ACCEPT NO IMITATIONS

### 10" PROFESSIONAL TILE SAW VX10.2XLPRO



**PATENTED TELESCOPING TABLE IS  
AVAILABLE ONLY FROM PEARL.**

<b>RIP CUT</b> 24" IN <b>DIAGONAL CUT</b> 18" IN	<b>POWERFUL</b> 2 HP MOTOR	<b>STAINLESS STEEL</b> SS WATER TRAY AND RAILS	<b>COMPACT</b> ONLY 24 in. LONG <b>LIGHTWEIGHT</b> ONLY 84 lbs. * TILE SAW ONLY
---	----------------------------------	--	---

*"THE SHERMAN TANK OF TILE SAWS!"*

#### PERFORMANCE DRIVEN FEATURES:

- Powerful 2 HP induction motor
- Over-sized, heavy duty stainless steel water tray for strength and durability
- Heavy duty on/off switch
- Stainless steel rail guides
- 10-sealed metal roller bearings
- Rubber-matted table

INCLUDED WITH SAW: Professional diamond blade, stainless water tray, drip tray, blade wrench, 45°/90° rip guide, water pump, miter block, Owner's manual.

One-year limited warranty

<b>MOTOR</b>	2 HP, 115v, 60Hz, single phase, 3,450 rpm With thermal overload protection
<b>CUTTING CAPACITY</b>	Depth of cut: Max. 3-1/4" Rip cut: 24" x 24" tile Angle cut: 18" x 18" tile
<b>BLADE CAPACITY</b>	8" - 10" with 5/8" arbor size
<b>WEIGHT (SAW ONLY)</b>	84 lbs.
<b>DIMENSION (SAW ONLY)</b>	(L)24" x (W)22-1/2" x (H)19-1/4" Water Tray = 37 in. long

**KIT**

PART# VX10.2XLPROKIT  
Includes: VX10.2XLPRO and V35010-UVXL Stand



WARNING: Cancer and reproductive harm  
www.P65Warnings.ca.gov

(\*) Indicates a special order item. Short lead times on most items. Please call for availability.  
To order, call: U.S.A. 800-969-5561 • Canada 800-387-0008 • PearlAbrasive.com

# PEARL

**10" TILE SAW**  
PA-10



<p>RIP CUT <b>24</b><sup>IN</sup></p> <p>DIAGONAL CUT <b>18</b><sup>IN</sup></p>	<p>POWERFUL <b>2</b> HP MOTOR</p>	<p>STAINLESS STEEL <b>SS</b> WATER TRAY</p>
--	---	---

"PRO TILE SAW AT A VALUE PRICE."

**FEATURES:**

- Steel frame and cast aluminum components
- Powerful 2 HP motor with thermal overload protection
- Belt driven blade shaft
- Over-sized, heavy duty stainless steel water tray for strength and durability
- Rubber-matted table

INCLUDED WITH SAW: Professional diamond blade, heavy duty stainless steel water tray (high durability tray for heavy-duty jobs), 45°/90° rip guide, universal wrench, water pump, Owner's manual.

One-year limited warranty

<b>MOTOR</b>	2 HP, 115v, 60Hz, single phase, 3,450 rpm with thermal overload protection
<b>CUTTING CAPACITY</b>	Depth of cut: Max. 3-1/4" Rip cut: 24" x 24" tile. Angle cut: 18" x 18" tile
<b>BLADE CAPACITY</b>	7" to 10" with 5/8" arbor blade
<b>WEIGHT</b>	73 lbs.
<b>DIMENSION</b>	(L)37" x (W)23" x (H)20"

**KIT** PART# PA-10KIT  
Includes: PA-10 and V35010-UVXL Stand



**7" PROFESSIONAL TILE SAW**  
PA-7PRO



<p>RIP CUT <b>20</b><sup>IN</sup></p> <p>DIAGONAL CUT <b>14</b><sup>IN</sup></p>	<p>POWERFUL <b>1</b> HP MOTOR HIGH TORQUE</p>	<p>COMPACT ONLY <b>33</b><sup>IN.</sup> LONG</p> <p>LIGHTWEIGHT ONLY <b>42</b> LBS.</p>
--	---	---

**FEATURES:**

- Powerful 1 HP motor
- Over-sized, heavy duty stainless steel water tray for strength and durability
- Rear water feed for minimal over spray
- 20" rip and 14" diagonal cut
- Steel frame and cast aluminum components

INCLUDED WITH SAW: Professional diamond blade, heavy duty stainless steel water tray (high durability tray for heavy-duty jobs), 45°/90° rip guide, universal wrench, water pump, Owner's manual.

One-year limited warranty

<b>MOTOR</b>	1 HP, 115v, 60Hz. 6,350 rpm
<b>CUTTING CAPACITY</b>	Depth of cut: Max. 3-1/4" Rip cut: 20" x 20" tile. Angle cut: 14" x 14" tile
<b>BLADE CAPACITY</b>	7" with 5/8" arbor blade
<b>WEIGHT</b>	42 lbs.
<b>DIMENSION</b>	(L)33" x (W)18.7" x (H)13" Water Tray = 37 in. long

**KIT** PART# PA-7PROKIT  
Includes: PA-7PRO and V35010-UV Stand



**10" RAIL SAW**  
VX10RS PRO

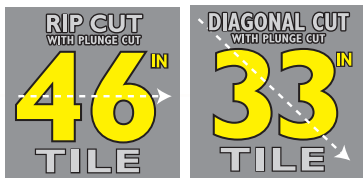

**NEW!**  
**10" RAIL SAW VX1048RS PRO**

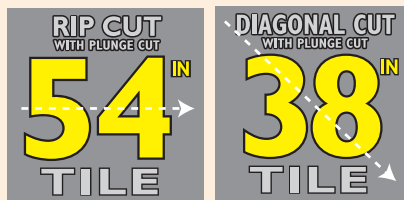

**FEATURES:**

- Powerful 1-1/2 HP motor
- Position lock cutting head
- Up to 1" plunge cut
- Rubber-matted cutting table
- Sturdy wheels for easy transport
- Splash guard reduces overspray
- Blade capacity of 10" enhances cutting capacity
- Removable extension table adds extra workspace
- Holes in the table divert water and waste material away from the work area. Water is recycled through these holes keeping it in the pan and off the floor

INCLUDED WITH SAW: Professional diamond blade, 45°/90° rip guide, multiple wrench, water pump, water level tube, table extension, drain plug, Owner's manual.

One-year limited warranty



2 HEAD HANDLES TO MOVE THE CUTTING HEAD EASILY!



LEGS FOLD UNDER SAW FOR EASY TRANSPORT.

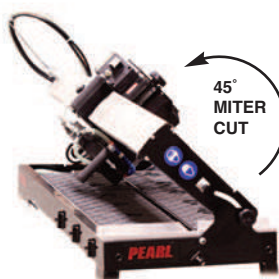

45° MITER CUT

<b>MOTOR</b>	1-1/2 HP, 115v, 60Hz, single phase 3,450 rpm, 60 Hz With thermal overload protection
<b>CUTTING CAPACITY</b>	Depth of Cut: (8" blade) 1-1/2" (10" blade) 2-5/8"
<b>BLADE CAPACITY</b>	8" - 10" with 5/8" arbor size
<b>WEIGHT</b>	VX10RS PRO = 172 lbs. VX1048RS PRO = 190 lbs.
<b>DIMENSION (Legs Folded)</b>	VX10RS PRO = (L)60" x (W)25" x (H)24" VX1048RS PRO = (L)66" x (W)24" x (H)27"



WARNING: Cancer and reproductive harm  
[www.P65Warnings.ca.gov](http://www.P65Warnings.ca.gov)

(\*) Indicates a special order item. Short lead times on most items. Please call for availability.  
To order, call: U.S.A. 800-969-5561 • Canada 800-387-0008 • PearlAbrasive.com





**IMPROVED!**  
**PORCELAIN**  
**REACTOR™**  
 with **ADM™ ADVANCED**  
**DIAMOND MATRIX**  
**TECHNOLOGY**

*Improved smooth diamond rim reduces chipping*

*Laser-cut core vents help cool the blade rim, promote fast, smooth cuts, longer life*

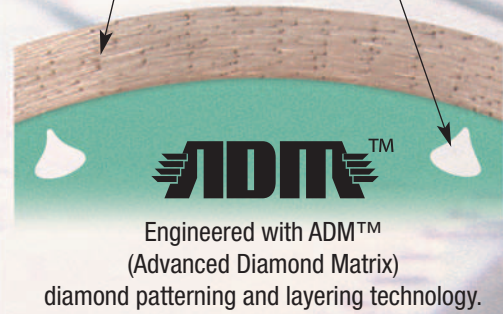

Pearl exclusive technology in tile/porcelain blades.  
 The only patterned porcelain tile blade in the industry!



- Engineered with ADM™ (Advanced Diamond Matrix) diamond patterning and layering technology provides faster cutting, smoother cuts and longer life than conventional porcelain blades.
- Thicker steel center than convention porcelain blades, provides less deflection, straighter smoother cuts, without sacrificing cutting speed.
- 10" and 14" blades have .080" thick core which helps with blade deflection without sacrificing cutting speed.

Small diameters 4", 4.5" & 5" can be used dry or wet.

PT. NUMBER	SPECS	MAX RPM
<b>NEW!</b> ADM04PT	4 x .060 x 20mm, 7/8, 5/8	13,700
ADM45PT	4-1/2 x .060 x 20mm, 7/8, 5/8	13,300
ADM05PT	5 x .060 x 20mm, 7/8, 5/8	12,200
ADM07PT	7 x .060 x 20mm, 7/8, 5/8	8,700
ADM08PT	8 x .060 x 1, 5/8	6,800
ADM10PT	10 x .080 x 1, 5/8	6,100
ADM1460PT	14 x .080 x 60/50mm	5,400

4" to 5" - 6.5mm rim • 7" to 10" - 9mm rim • 14" - 9.5 mm rim

APPLICATIONS: For Porcelain, Extra Hard Tile, Ceramic Tile, Natural Stone, Granite, Hard Tile, Hard Ceramics and Metal Tiles.

**FAST, CLEAN AND CONSISTENT FROM FIRST TO LAST CUT!**

# PORCELAIN

For Porcelain, Extra Hard Tile, Ceramic Tile, Natural Stone, Granite, Hard Tile, Hard Ceramics.

## P4™ PORCELAIN



PT. NUMBER	SPECS	MAX RPM
DTL04HPXL	4 x .060 x 20mm, 7/8, 5/8	13,700
DTL45HPXL	4-1/2 x .060 x 7/8, 5/8	13,300
DTL07HPXL	7 x .060 x 5/8	8,500
DTL08HPXL	8 x .060 x 5/8	6,800
DTL10HPXL	10 x .060 x 5/8	6,100

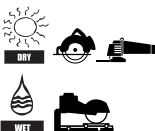

## P5™ PORCELAIN



PT. NUMBER	SPECS	MAX RPM
DIA04HP	4 x .060 x 20mm, 7/8, 5/8, 13,700	
DTL07HP	7 x .060 x 5/8	8,500
DTL08HP	8 x .060 x 5/8	6,800
DTL10HP	10 x .060 x 5/8	6,100

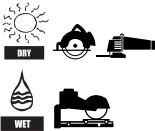

# GRANITE

For Granite, Porcelain, Hard Tile, Natural Stone, Artificial Stone.

## P5™ GRANITE



PT. NUMBER	SPECS	MAX RPM
DIA04GRT	4 x .070 x 20mm, 5/8	13,700
DIA04GR4	4 x .070 x 20mm, 4-holes	13,700
DIA45GRT	4-1/2 x .080 x 7/8, 5/8	13,300
DIA45GR4	4-1/2 x .080 x 20mm, 4-holes	13,300
DIA05GRT	5 x .080 x 7/8, 5/8	12,200
DIA05GR4	5 x .080 x 20mm, 4-holes	12,200
DIA06GRT	6 x .080 x 7/8, 5/8	10,200
DIA06GR4	6 x .080 x 20mm, 4-holes	10,200
DIA07GRT	7 x .080 x 7/8, 5/8	8,500
DIA07GR4	7 x .080 x 20mm, 4-holes	8,500

GRANITE BLADE ADAPTER FOR FLUSH CUTTING



# PORCELAIN / GRANITE

For Porcelain, Granite, Hard Tile, Natural Stone.

## THIN TURBO MESH BLADES

### P3™ TURBO-X MESH



PEARL EXCLUSIVE "X-RIM" DESIGN!



PT. NUMBER	SPECS
DIA04TX	4 x .055 x 7/8, 20mm, 5/8
DIA45TX	4-1/2 x .055 x 7/8, 20mm, 5/8
DIA05TX	5 x .055 x 7/8, 20mm, 5/8
DIA07TX	7 x .063 x 7/8, 5/8
DIA10TX	10 x .071 x 7/8, 20mm, 5/8

### P4™ TURBO MESH

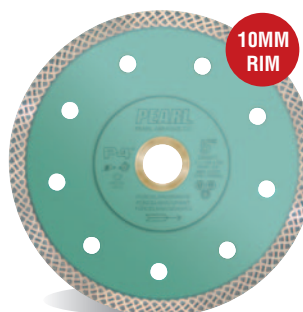

PT. NUMBER	SPECS
DIA04TT	4 x .048 x 7/8, 20mm, 5/8
DIA45TT	4-1/2 x .048 x 7/8, 20mm, 5/8
DIA05TT	5 x .048 x 7/8, 20mm, 5/8
DIA06TT	6 x .048 x 5/8, 20mm, 7/8
DIA07TT	7 x .055 x 7/8, 5/8
DIA10TT	10 x .063 x 7/8, 20mm, 5/8
DIA14TT	14 x .095 x 60, 50mm

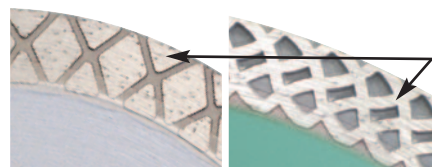

P3™ TURBO-X

P4™

Turbo mesh rim virtually eliminates heat caused by friction

- Thin turbo-mesh rim and core for fast cutting and minimal chipping
- Fast cutting
- Extra long life
- Wet or dry cutting
- Ideal for cutting extra hard ceramics, porcelain and other hard/dense materials
- 10 and 14" wet cutting only

### P5™ PORCELAIN/GRANITE



PT. NUMBER	SPECS	MAX RPM
DIA04SHD	4 x .060 x 20mm, 5/8	13,700
DIA45SHD	4-1/2 x .060 x 7/8, 5/8	13,300
DIA05SHD	5 x .060 x 7/8, 5/8	12,200
DIA07SHD	7 x .070 x 7/8, 5/8	8,500
DIA08SHD	8 x .070 x 5/8	6,800



WARNING: Cancer and reproductive harm  
www.P65Warnings.ca.gov

(\* Indicates a special order item. Short lead times on most items. Please call for availability.  
To order, call: U.S.A. 800-969-5561 • Canada 800-387-0008 • PearlAbrasive.com

# GLASS TILE

For Glass Tiles, Ultra Hard Ceramics, Ceramic & Quartz Tubing, Granite Tiles, Rods and Onyx.

## P5™ GLASS TILE - RESIN BOND

Resin Bond diamond blades offer superior cut quality over other diamond blades. They are essential in applications that require a smooth finish and minimal chipping.

- Supreme-grade resin bond for production glass cutting and to eliminate breakout when cutting glass tiles or glass tubing
- Chip-free cutting, precise and smooth finish
- Wet cutting

7", 8" & 14" - 7mm rim  
10" - 10mm rim



PT. NUMBER	SPECS	MAX RPM
DTL07RBG	7 x .062 x 5/8	5,300
DTL08RBG	8 x .062 x 5/8	4,600
DTL10RBG	10 x .070 x 5/8, 1	3,700
DTL14RBG	14 x .070 x 1	2,700

WATCH THE VIDEO AT:  
[PearlAbrasive.com](http://PearlAbrasive.com)

Resin Bond blades should never be used at rpms higher than the maximum rpm shown on Pearl literature and blades. Please check your saw before installing the blade. Pearl tile saws operate at the correct rpms for Resin Bond blades. These blades are more susceptible to impact damage than standard metal bond blades. Extra care should be taken to protect the blades when mounting, operating or storing. Always supply sufficient amount of water to keep the blade cool. Misting or table water feeds are not sufficient. When cutting, gently feed the tile through the cut. Do not force.

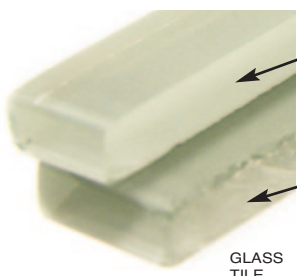

Chip-free cutting with resin bond diamond blade

Results of cutting with metal bond diamond blade

GLASS TILE

## P5™ GLASS TILE



PT. NUMBER	SPECS	MAX RPM
NEW! DTL45G	4-1/2 x .060 x 7/8, 20mm, 5/8	8,500
DTL07G	7 x .048 x 5/8	8,500
DTL10G	10 x .048 x 5/8	6,100

# GRANITE

For Granite, Porcelain, Natural Stone, Artificial Stone.

## P5™ GRANITE ADM™ TECHNOLOGY



Engineered with ADM™ (Advanced Diamond Matrix) diamond patterning and layering technology

PT. NUMBER	SPECS	MAX RPM
HB114RA5	1-1/4 x 3 x 5/8-11	10,000
HB138RA5	1-3/8 x 3 x 5/8-11	10,000
HB112RA5	1-1/2 x 3 x 5/8-11	10,000
HB200RA5	2 x 3 x 5/8-11	10,000

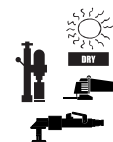

## P4™ GRANITE ADM™ TECHNOLOGY



Engineered with ADM™ (Advanced Diamond Matrix) diamond patterning and layering technology

PT. NUMBER	SPECS	MAX RPM
HB114RA4	1-1/4 x 3-1/4 x 5/8-11	10,000
HB138RA4	1-3/8 x 3-1/4 x 5/8-11	10,000
HB112RA4	1-1/2 x 3-1/4 x 5/8-11	10,000
HB200RA4	2 x 3-1/4 x 5/8-11	10,000



# TILE / MARBLE

For Tile, Ceramic Tile, Marble, Granite.

## P4™ TILE / MARBLE



PT. NUMBER	SPECS	MAX RPM
HB100L2	1 x 2-1/4 x 3/8	1,200
HB114L2	1-1/4 x 2-1/4 x 3/8	1,200
HB138L2	1-3/8 x 2-1/4 x 3/8	1,200
HB112L2	1-1/2 x 2-1/4 x 3/8	1,200
HB200L2	2 x 2-1/4 x 3/8	1,200
HBCPL2	Center point for core bit	

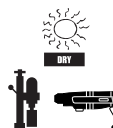



# TILE / STONE

For Tile, Ceramic Tile, Porcelain, Marble, Granite, Glass.

## P4™ TILE / STONE



- Vacuum brazed bond for fast, clean, chip-free drilling
- Long life
- Remove material plugs quickly, easily
- For tile, stone, and glass applications
- Use wet for best results
- 1" maximum cutting depth
- 1/4" quick change hex shank



PT. NUMBER	SPECS	MAX RPM
CDP3-16	3/16 x 1/4	2,500
CDP1-4	1/4 x 1/4	2,500
CDP9-32	9/32 x 1/4	2,500
CDP5-16	5/16 x 1/4	2,500
CDP3-8	3/8 x 1/4	2,500
CDP1-2	1/2 x 1/4	2,500
CDP5-8	5/8 x 3/8	2,500

# GRANITE

## 4" POLISHING PADS HOOK & LOOP BACKING

For granite, terrazzo, natural stone, marble. Available in 50, 100, 200, 400, 1000, 2000, BUFF grits. Max 4,200 rpm

Also available in kit.

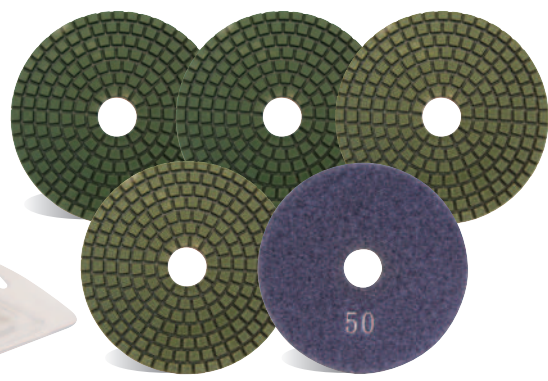

PT. NUMBER	SPECS	MAX RPM
SPS47KIT	incl. 1 ea. (50, 100, 200, 400, 800, 1500 & 3000)	
SPS4050	50 grit	4,200
SPS4100	100 grit	4,200
SPS4200	200 grit	4,200
SPS4400	400 grit	4,200
SPS4800	800 grit	4,200
SPS41500	1500 grit	4,200
SPS43000	3000 grit	4,200

# GreenSkin Flooring Underlayment Membrane

## ULTIMATE CRACK & MOISTURE PROTECTION

GreenSkin™ Flooring is an Innovative, Self-Adhering Underlayment Membrane, For a Primerless Installation!

### FAST PEEL-AND-STICK INSTALLATION!

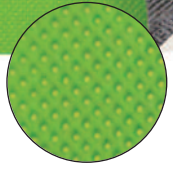
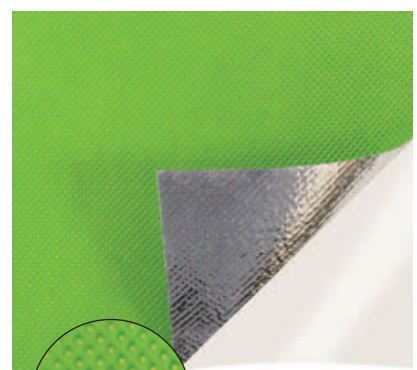

**High Strength Water Tight Membrane**

**40 mil thick  
Super Sticky PSA/Glue  
with Zero VOC's/Solvents  
Peel and Stick Technology  
for Smooth Installation**



1  
Wet Mop Clean to Prepare Surface (No Need to Prime)

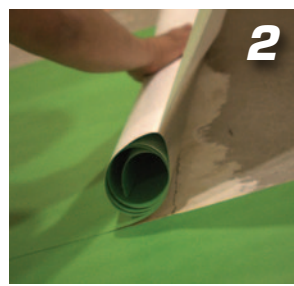

2  
Remove Backing and GreenSkin™ Adheres Directly to Substrate



3  
Lay Thinset and Flooring Directly on GreenSkin™

- Extremely High Crack Strength
- Primerless Process Saves You Time and Money
- 40% Lighter Than Typical Noxious Asphalt Underlayments
- 100% Recycled Material, and 100% Made in the U.S.A.!
- Available in 36" x 75' and 18" x 75' sizes.





**TRU-SPACE™**

**TILE LEVELER + SPACER  
ALL-IN-ONE!**

ELIMINATES EXTRA STEPS,  
PIECES, AND COST!



**1-PIECE  
SYSTEM THAT  
VIRTUALLY  
ELIMINATES  
LIPPAGE  
DURING TILE  
INSTALLATION.**

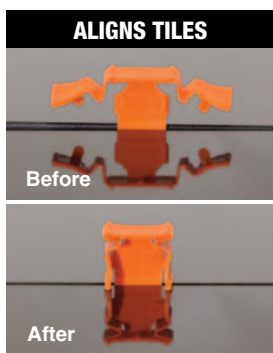

**COLOR CODED FOR EASY IDENTIFICATION**  
For gauged tiles 3/8" to less than 1/2" thick (9.5mm to 12mm)

ORIGINAL



**Red Tuscan  
SeamClip™**  
GROUT SIZE:  
1/32" (.80 MM)

PT. NUMBER	SPECS
TSC150R	150 / Box
TSC500R	500 / Box
TSC1000R	1000 / Box



**Orange Tuscan  
SeamClip™**  
GROUT SIZE:  
1/16" (1.59 MM)

PT. NUMBER	SPECS
TSC150116O	150 / Box
TSC500116O	500 / Box
TSC1000116O	1000 / Box



**Green Tuscan  
SeamClip™**  
GROUT SIZE:  
1/8" (3.18 MM)

PT. NUMBER	SPECS
TSC15018G	150 / Box
TSC50018G	500 / Box
TSC100018G	1000 / Box



**Purple Tuscan  
SeamClip™**  
GROUT SIZE:  
3/16" (4.76 MM)

PT. NUMBER	SPECS
TSC150316P	150 / Box
TSC500316P	500 / Box
TSC1000316P	1000 / Box

- Adds grout joints during tile installation.
- Grout sizes in 1/32", 1/16", 1/8" and 3/16".
- The fastest, easiest system to use!  
No tools needed!
- Made in the U.S.A. (Midwest) from recyclable material.

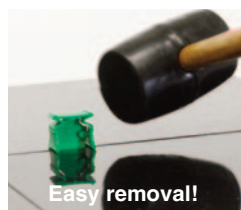

U.S. Pat. No.  
8,820,031



Also available:

**For gauged tiles 1/4" to less than 3/8" thick  
(6mm to 9mm)**



**Blue Tuscan  
SeamClip™**  
GROUT SIZE:  
1/32" (.80 MM)

PT. NUMBER	SPECS
TSC150B	150 / Box
TSC500B	500 / Box
TSC1000B	1000 / Box

**For large format thin ceramic tile.  
Gauged tiles 1/8" to less than 1/4" thick (3mm to 6mm)**



**White Tuscan  
SeamClip™**  
GROUT SIZE:  
1/32" (.80 MM)

PT. NUMBER	SPECS
TSC150W	150 / Box
TSC500W	500 / Box
TSC1000W	1000 / Box



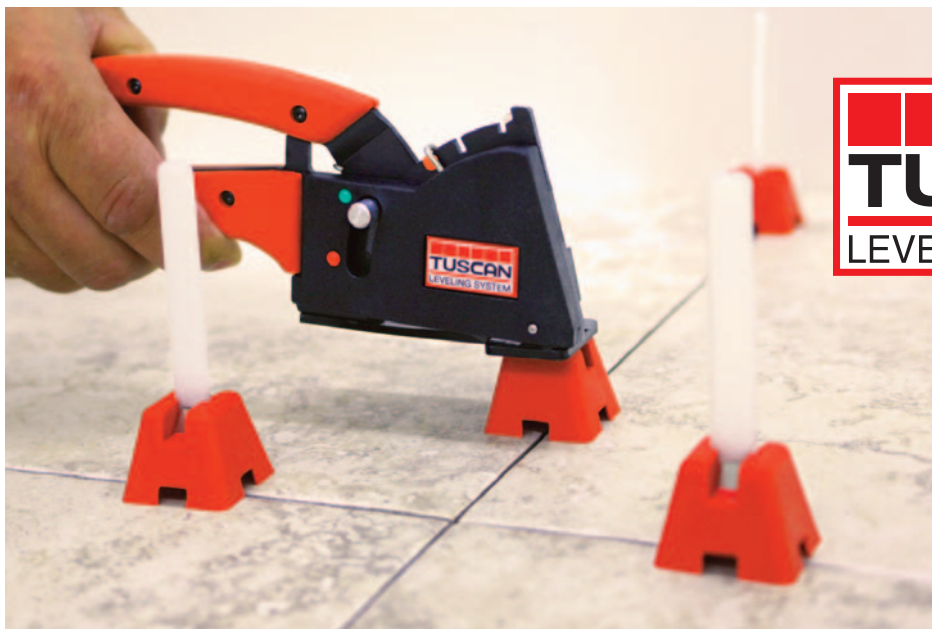

**2-PIECE SYSTEM THAT VIRTUALLY ELIMINATES LIPPAGE DURING TILE INSTALLATION.**

**VIRTUALLY ELIMINATES LIPPAGE ON WALLS AND FLOORS!**

- Passes standard industrial (TCNA Robinson) compression test.
- Very easy to learn and use at any skill level.
- Prevents tiles from moving while curing.
- More profitable for the installer.
- Re-usable caps.
- Recommended for gauged tiles 12" or larger.
- Reduces installer fatigue/stress.
- Virtually lippage free, flat surface drastically reduces the need for grinding and polishing.
- Strap (TLSSTRAP) is designed to be used on tiles of uniform thickness only (gauged tile).
- Wing Strap (TLSWSTRAP) is designed to be used on ungauged tile with up to 2mm difference.

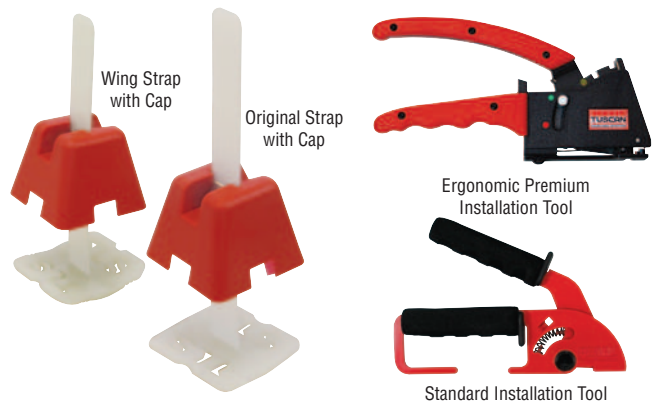

PT. NUMBER	SPECS
TLSSTRAP200	200 Straps/Box
TLSSTRAP500	500 Straps/Bucket
TLSSTRAP1000	1000 Straps/Box
TLSWSTRAP500	500 Wing Straps/Box
TLSWSTRAP1000	1000 Wing Straps/Box
TLSCAP200	200 Re-usable Caps/Bucket
TLSCAP500	500 Re-usable Caps/Bucket



**Also available: WING STRAP**

- Designed to help virtually eliminate lippage in **ungauged tile** with up to 2mm difference.
- 1/2" notched trowel (or greater) recommended.
- Ideal for flat surfaces.

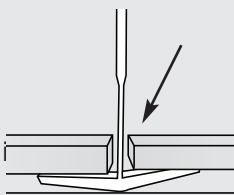

PATENT PENDING

WATCH THE VIDEO AT: [PearlAbrasive.com](http://PearlAbrasive.com)

**ACCESSORIES**

TLSGUNST	Standard Installation Tool
TLSEGGUNKIT	Ergonomic Performance Installation Tool Kit Includes: Installation tool, holster and case
TLSEGGUNPR	Ergonomic Premium Installation Tool with case



WARNING: Cancer and reproductive harm  
[www.P65Warnings.ca.gov](http://www.P65Warnings.ca.gov)

(\*) Indicates a special order item. Short lead times on most items. Please call for availability.  
To order, call: U.S.A. 800-969-5561 • Canada 800-387-0008 • PearlAbrasive.com

# SMART SPACER®

THE PROFESSIONAL'S CHOICE!

- Consistent spacing
- Won't tip or twist like others
- Rigid for consistent wall spacing
- 3 convenient sizes in one
- Reusable, quick, clean material

Superior  
for Wall  
and Floor  
Installations

Made in the  
USA of  
recycled  
material

3-IN-1  
Smart Spacers®  
have 3 sizes in 1  
easy to use  
product.



## INCREASES PRODUCTIVITY

Smart Spacers® roll as tiles are adjusted. They can't twist corner to corner or tip over freeing you to install rather than realigning and readjusting spacers.

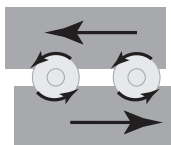

## CONSISTENT EVEN SPACING

The round pegs and disc of the Smart Spacer® maintain even spacing when tiles are moved. Other spacers often twist or fall over while tiles are being adjusted resulting in uneven and inconsistent grout lines.

**WON'T COMPRESS** - Smart Spacers® are made of rigid polypropylene (they won't compress when stacking walls or laying a floor).

**CLEAN INSTALL** - Other spacers get messy and are difficult to remove from grout.

**EASY TO CLEAN** - Smart Spacers® are made of polypropylene, they are easy to clean.

PT. NUMBER	SPECS
SS200SM	Small (200/pack) • 1/8, 1/16, 3/16"
SS100LG	Large (100/pack) • 1/4, 5/16, 3/8"



WATCH THE VIDEO AT:  
[PearlAbrasive.com](http://PearlAbrasive.com)

Tile stripper and jackhammer  
sold separately

# EASY HAMMER® TROLLEY

The Easy Hammer® trolley is an innovative tool for fast and easy removal on a variety of flooring including ceramic tile, vinyl, wood, cork and much more.

No more struggling with trying to handle heavy jackhammers. Trolley weight: 65 lbs.

*EASIER AND MORE EFFECTIVE THAN USING A JACKHAMMER ALONE!*

## 5 Adjustable Positions!

The Easy Hammer® trolley can be easily adjusted to 5 different positions and is suited for most demolition jobs.

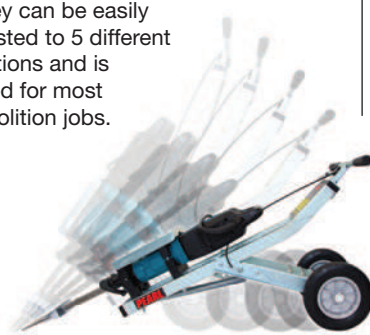

### #PA01HT Hammer Trolley for:

- Bosch® 11335K
- Dewalt® D25960K
- Hitachi® H65SD2
- Milwaukee® 5337-21
- Makita® HM1317CB
- Makita® HM1307CB

### #PA01HTB Hammer Trolley for:

- Bosch® Brute BH2760 65 lbs.

### #PA01HTH Hammer Trolley for:

- Hilti® TE1000
- Hilti® TE1500

### #PA01HTM Hammer Trolley for:

- Makita® HM1810 65 lbs.

Special Order Only

## TILE STRIPPERS AND BLADE

Heavy duty. Rugged scraper blade for removing tile, linoleum, wood and other floor products. Heavy duty hardened 11" shank and bolts to secure blade in place.

### NOW WITH THREADED SHANK

With the NEW THREADED SHANK, operator can remove and replace shank unlike the tapered shank.



### PA02TSE

2-piece heavy duty, die-cast machined head. (include shank 1-1/8" hex, head and blade)



### PA02TS

1-piece heavy duty head. (include shank 1-1/8" hex, head and blade)



**PA02RB**  
Replacement Blade

**PA02TSTS**  
Threaded Shank only

**PA02TSBTS**  
Nut only